

LPF-F ELECTRIC PRESSURE FRYER

Designed for simple, safe, economical operation, BKI's electric pressure fryers enhance fried food operations and increase food quality. Controlled low pressure-cooking delivers moist, tender fried food with a 30% longer holding capability. Patented "Quick-Connect" filtration system improves operations through a fail-safe alignment feature, while the built-in cold zone collects breading "fall-off" to extend shortening life for a substantial savings. Highest quality construction stands up to heavy use. Exceptional pricing makes the BKI electric pressure fryer the profitable, value choice for any retail or catering business.



STANDARD FEATURES

- o Patented "Quick-Disconnect" filter assembly
- o Lid interlock safety design
- o High-pressure release valve
- o Casters for easy mobility
- o Capacity – 23 litres (liquid oil)
- o Round well for easy cleaning

OPTIONS FOR SPECIFICATION

- o Microprocessor with 8 program modes

ACCESSORIES

- o Tiered basket
- o Open basket



Specifications subject to change without notice.



Experts in Heat Transfer Technology®



www.bkideas.co.uk

BKI Europe

Theale Technology Centre
Station Road · Theale · Reading
West Berkshire · RG7 4AA
Tel: + 44 (0)870 9904242 · Fax: + 44 (0)870 9904243
Email: sales@bkideas.co.uk · website: www.bkideas.co.uk

BKI North America

Tel: + (1) 864 9633471
Fax: + (1) 864 9672787

LPF-F ELECTRIC PRESSURE FRYER

SPECIFICATIONS

DIMENSIONS

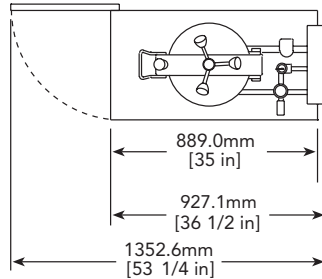

TOP VIEW

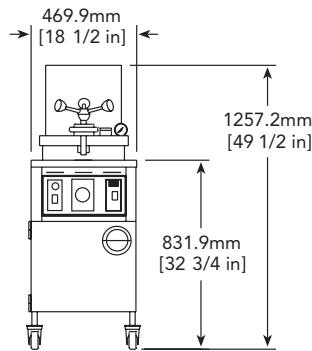

FRONT VIEW

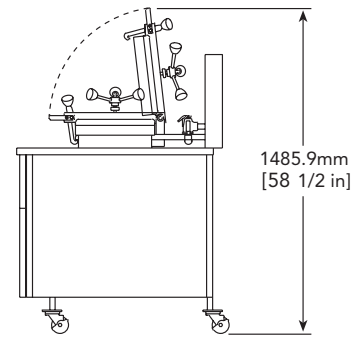

RIGHT SIDE VIEW

FLOOR SPACE

.44 m² (4.7 sq.ft)

CAPACITY

23 L (liquid oil)

SHIPPING WEIGHT

145.2 kg (320 lb.)

ELECTRICAL

ELECTRICAL SPECIFICATIONS

Volts	Amps	Breaker	KW	Wires	Phase
208	38/65	50/80	13.5	3/2	3/1
400/230	33/57	50/70	13.5	3/2	3/1

© BKI Ref. BKI/LDP/006/12.04 Specifications subject to change without notice.



Experts in Heat Transfer Technology®



www.bkideas.co.uk

BKI Europe

Theale Technology Centre
 Station Road · Theale · Reading
 West Berkshire · RG7 4AA
 Tel: + 44 (0)870 9904242 · Fax: + 44 (0)870 9904243
 Email: sales@bkideas.co.uk · website: www.bkideas.co.uk

BKI North America

Tel: +(1) 864 9633471
 Fax: +(1) 864 9672787